

F3

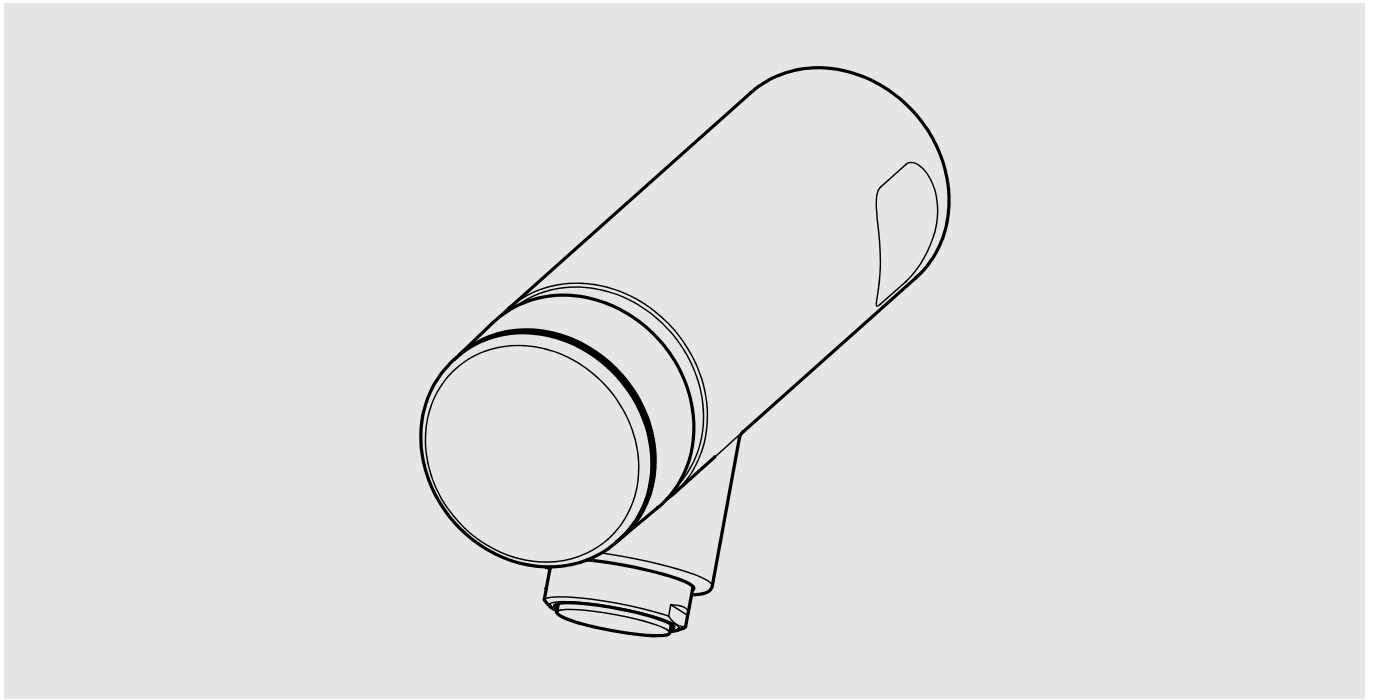

F3SV1002
2030034413
7612982236648

DE	Montage- und Betriebsanleitung	Selbtschluss-Wandventil
EN	Installation and operating instructions	Self-closing valve wall mounted
FR	Notice de montage et de mise en service	Robinet mural à fermeture automatique
ES	Instrucciones de montaje y servicio	Válvula de pared con cierre automático
IT	Istruzioni per il montaggio e l'uso	Valvola a parete temporizzata
NL	Montage- en bedrijfsinstructies	Zelfsluitende wandkraan
PL	Instrukcja montażu i obsługi	Samozamykająca bateria ścienna
SV	Monterings- och driftinstruktion	
CS	Návod pro montáž a provoz	samouzavírací nástěnný ventil
FI	Asennus- ja käyttöohje	Itsesulkeutuva seinäventtiili
RU	Инструкция по монтажу и вводу в эксплуатацию	

*Make
it
Wonderful*

FRANKE

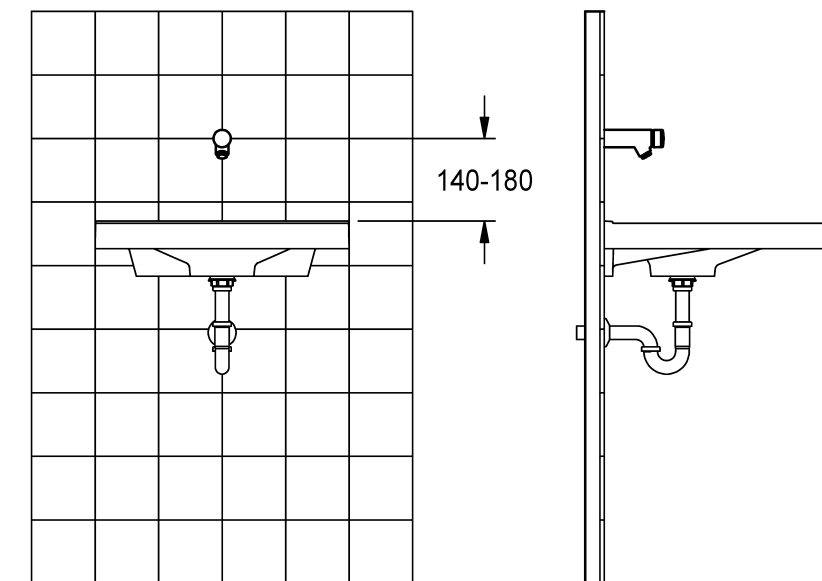
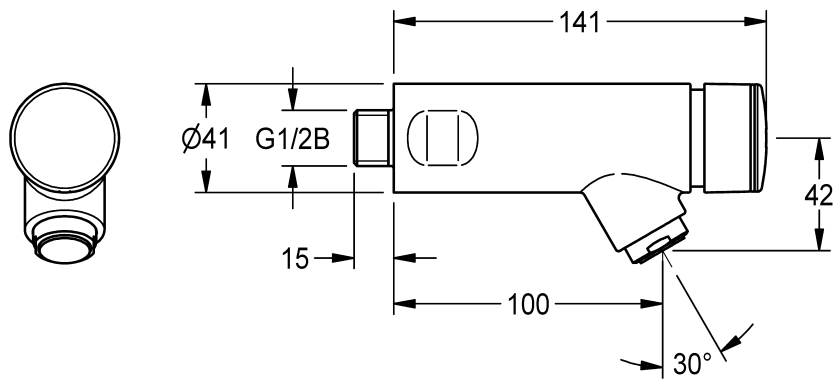
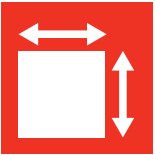
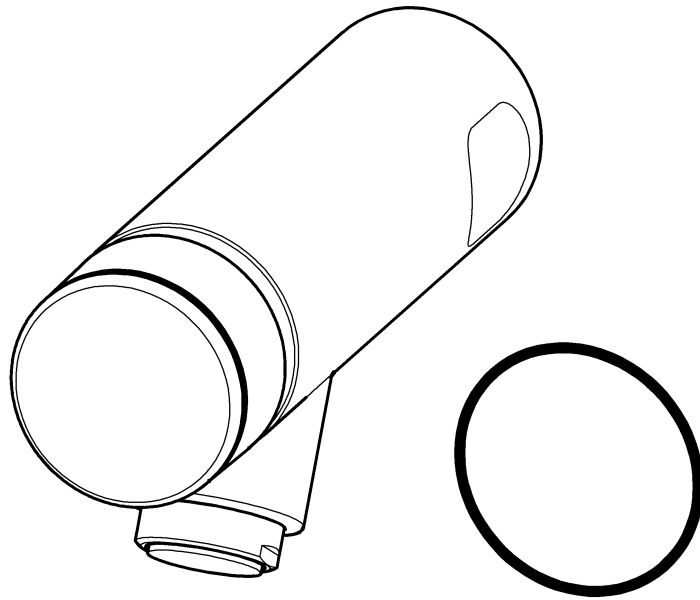

EN

Installation and operating instructions

Important notes

- ▶ Before installing flush piping system!
- ▶ The fitting must be checked and maintained at regular intervals depending on the water quality and in accordance with the local conditions, and rules and regulations applicable at the site.
- ▶ Install a revisable sieve on site.

Technical data

- ▶ Minimum flow pressure 1.0 bar
- ▶ Maximum operating pressure 10 bar
- ▶ Recommended flow pressure 3 bar
- ▶ Volume flow 3 l/min
- ▶ Flow duration 5-20 s adjustable

PL

Instrukcja montażu i obsługi

Ważne wskazówki

- ▶ Przed instalacją przepłukać rury!
- ▶ Armaturę należy poddawać regularnej kontroli i konserwacji w zależności od jakości wody, warunków lokalnych i obowiązujących przepisów.
- ▶ Zainstalować sitko nadające się do kontroli.

Dane techniczne

- ▶ Minimalne ciśnienie przepływu 1,0 bar
- ▶ Maksymalne ciśnienie robocze 10 barów
- ▶ Zalecane ciśnienie przepływu 3 barów
- ▶ Objętościowe natężenie przepływu 3 l/min
- ▶ Czas przepływu 5-20 s z możliwością ustawienia

DE

Montage- und Betriebsanleitung

Wichtige Hinweise

- ▶ Vor Installation Rohrleitungen spülen!
- ▶ In Abhängigkeit von der Wasserqualität, den örtlichen Gegebenheiten und den vor Ort geltenden Bestimmungen die Armatur in regelmäßigen Abständen prüfen und warten.
- ▶ Bauseits ein revisionsfähiges Sieb installieren.

Technische Daten

- ▶ Mindestfließdruck 1,0 bar
- ▶ Maximaler Betriebsdruck 10 bar
- ▶ Empfohlener Fließdruck 3 bar
- ▶ Volumenstrom 3 l/min
- ▶ Fließzeit 5-20 s einstellbar

SV

Monterings- och driftinstruktion

Viktiga informationer

- ▶ Spola igenom rörledningarna före installation!
- ▶ Kontrollera och serva armaturen med intervaller som bestäms av vattenkvaliteten samt de lokala förhållandena och de bestämmelser som gäller där.
- ▶ Installera en kontrollerbar sil på monteringsplatsen.

Tekniska data

- ▶ Minsta hydrauliska tryck 1,0 bar
- ▶ Maximalt driftryck 10 bar
- ▶ Rekommenderat hydrauliskt tryck 3 bar
- ▶ Volymström 3 l/min
- ▶ Flyttid 5-20 s inställbar

FR

Notice de montage et de mise en service

Remarques importantes

- ▶ Rincer les conduites avant d'installer !
- ▶ En fonction de la qualité de l'eau, ainsi que des conditions et des dispositions locales, il convient de contrôler et d'entretenir la robinetterie à intervalles réguliers.
- ▶ Le client doit installer un filtre pouvant faire l'objet d'une révision.

Données techniques

- ▶ Pression dynamique minimale 1,0 bar
- ▶ Pression de service maximale 10 bars
- ▶ Pression dynamique recommandée 3 bars
- ▶ Débit volumique 3 l/min
- ▶ Durée d'écoulement 5-20 s réglable

ES

Instrucciones de montaje y servicio

Indicaciones importantes

- ▶ ¡Enjuagar las tuberías antes de instalar!
- ▶ En función de la calidad del agua, las condiciones locales y la legislación vigente, realizar las inspecciones y el mantenimiento de la grifería a intervalos regulares.
- ▶ El cliente debe instalar un filtro inspeccionable.

Datos técnicos

- ▶ Presión mínima de flujo 1,0 bar
- ▶ Presión máxima de servicio 10 bares
- ▶ Presión de flujo recomendada 3 bares
- ▶ Flujo volumétrico 3 l/min
- ▶ Tiempo de corriente 5-20 s ajustable

CS

Návod pro montáž a provoz

Důležité pokyny

- ▶ Před instalací potrubí propláchněte!
- ▶ V závislosti na kvalitě vody, místních podmínkách a předpisech platných v místě instalace je nutné provádět v pravidelných intervalech kontrolu a údržbu armatury.
- ▶ Na místě instalace nainstalujte reverzní sítko.

Technické údaje

- ▶ Minimální průtočný tlak 1,0 bar
- ▶ Maximální provozní tlak 10 bar
- ▶ Doporučený průtočný tlak 3 bar
- ▶ Průtok 3 l/min
- ▶ Doba průtoku nastavitelná 5-20 s

FI

Asennus- ja käyttöohje

Tärkeitä ohjeita

- ▶ Huuhtele putkijohdot ennen asennusta!
- ▶ Hana tulee tarkistaa ja huoltaa säännöllisin väliajoin veden laadusta, paikallisista oloista ja paikalla voimassa olevista määräyksistä riippuen.
- ▶ Asenna rakennukseen puhdistettavissa oleva sihti.

Tekniset tiedot

- ▶ Vähimmäisvirtauspaine 1,0 bar
- ▶ Suurin käyttöpaine 10 bar
- ▶ Suositeltava virtauspaine 3 bar
- ▶ Tilavuusvirta 3 l/min
- ▶ Juoksuaika 5-20 s säädettävissä

IT

Istruzioni per il montaggio e l'uso

Avvertenze importanti

- ▶ Sciacquare le tubazioni prima di installare!
- ▶ Controllare e sottoporre a manutenzione l'apparecchio ad intervalli regolari, in funzione della qualità dell'acqua, delle caratteristiche locali e delle vigenti disposizioni locali.
- ▶ Installare in loco un filtro ispezionabile.

Specifiche tecniche

- ▶ Pressione idraulica min. 1,0 bar
- ▶ Pressione di esercizio max. 10 bar
- ▶ Pressione idraulica consigliata 3 bar
- ▶ Portata volumetrica 3 l/min
- ▶ Durata di flusso impostabile da 5 a 20 s

NL

Montage- en bedrijsinstructies

Belangrijke aanwijzingen

- ▶ Voor installatie buisleidingen spoelen!
- ▶ Afhankelijk van de waterkwaliteit, de plaatselijke omstandigheden en de plaatselijke voorschriften de armatuur regelmatig controleren en onderhouden.
- ▶ Monteer op de bouwlocatie een vervangbare zeef.

Technische gegevens

- ▶ Minimale dynamische druk 1,0 bar
- ▶ Maximale werkdruk 10 bar
- ▶ Aanbevolen dynamische druk 3 bar
- ▶ Volumestroom 3 l/min
- ▶ Stroomingstijd 5-20 s instelbaar

RU

Инструкция по монтажу и вводу в эксплуатацию

Важные указания

- ▶ Перед инсталляцией промыть трубки!
- ▶ Арматуру необходимо регулярно чистить и обслуживать в зависимости от качества воды, местных условий и действующих в месте эксплуатации предписаний.
- ▶ Установку сетки с доступом для осмотра обеспечить заказчику.

Технические характеристики

- ▶ Минимальный гидравлический напор 1,0 бар
- ▶ Максимальное рабочее давление 10 бар
- ▶ Рекомендуемый гидравлический напор 3 бар
- ▶ Объемный расход 3 л/мин
- ▶ Время протекания 5-20 сек. регулируемое

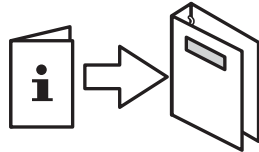
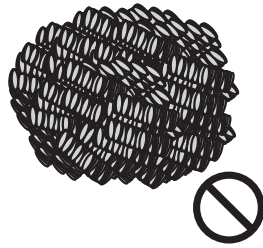

www.franke.com

1. Montage

EN Installation
FR Montage
ES Montaje
IT Montaggio

NL Montage
PL Montaż
SV Montering

CS Montáž
FI Asennus
RU Монтаж
AR



 36 mm

1

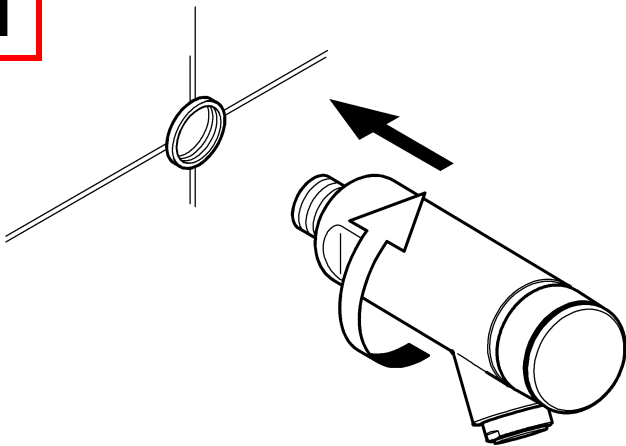

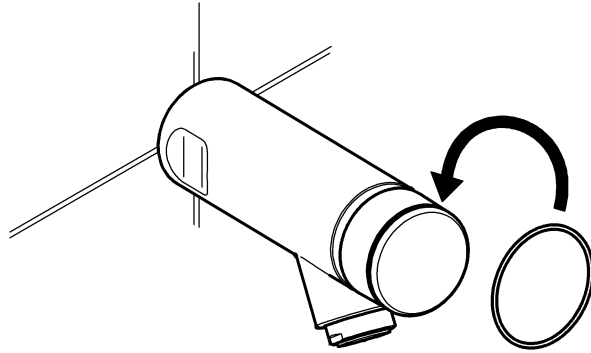
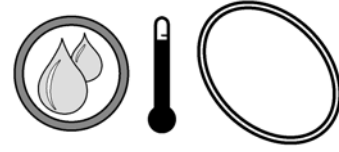
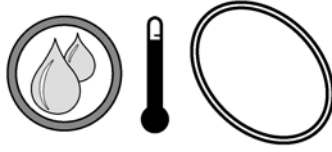
2**I** Red**II** Blue

EN | Red
II Blue

ES | Rojo
II Azul

PL | Czerwony
II Niebieski

FI | Punainen
II Sininen

DE | Rot
II Blau

IT | Rosso
II Blu

SV | Röd
II Blå

RU | красный
II голубой

FR | Rouge
II Bleu

NL | Rood
II Blauw

CS | Červený
II Modrý

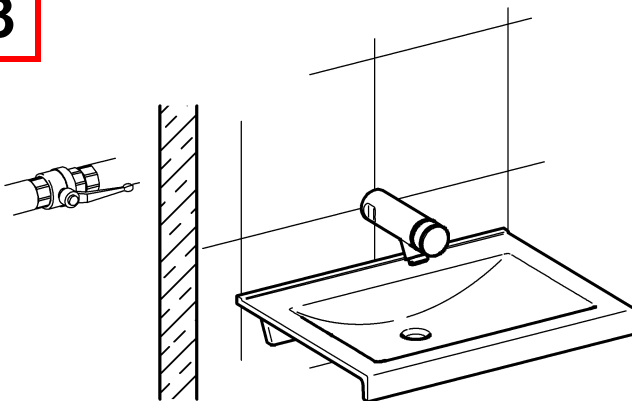
3

2. Funktion

EN Function
FR Fonctionnement
ES Función
IT Funzionamento

NL Werking
PL Funkcja
SV Funktion

CS Funkce
FI Toiminto
RU Функционирование
AR

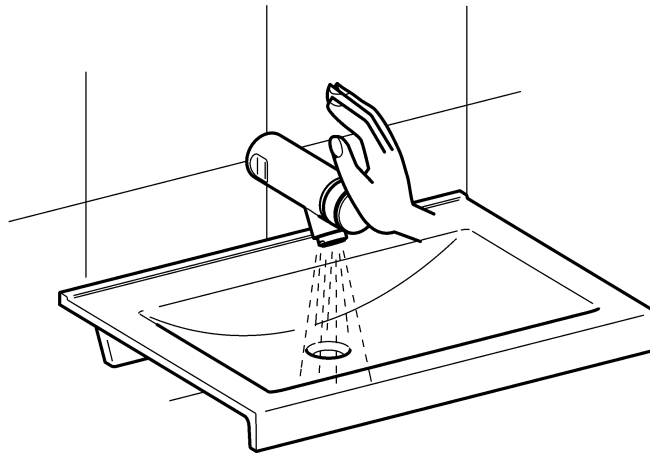

3. Fließzeit einstellen

EN Adjust flow duration
FR Régler la durée d'écoulement
ES Ajustar el tiempo de flujo
IT Impostazione della durata di flusso

NL Stroomingstijd instellen
PL Ustawić czas przepływu
SV Ställa in flytförmígan

CS Nastavit dobu průtoku
FI Aseta virtausaika
RU Регулировка времени истечения



3 mm

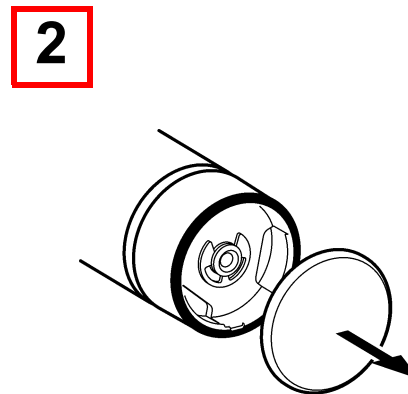
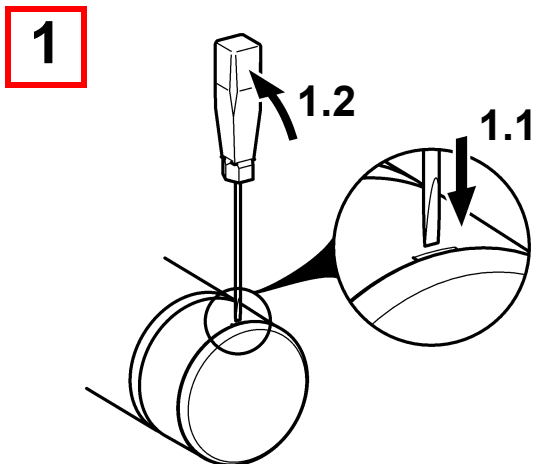

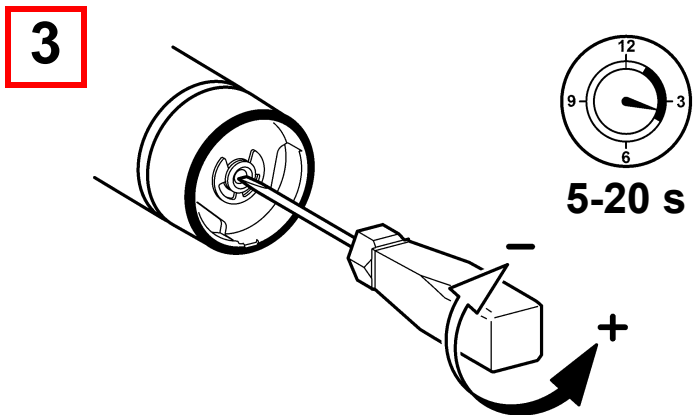

4. Wartung

EN Maintenance
FR Maintenance
ES Mantenimiento
IT Manutenzione

NL Onderhoud
PL Konserwacja
SV Underhåll

CS Varování
FI Huolto
RU Техническое обслуживание



22 mm

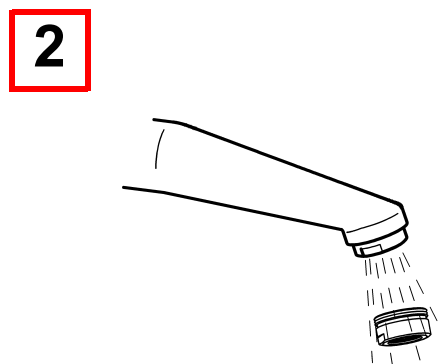
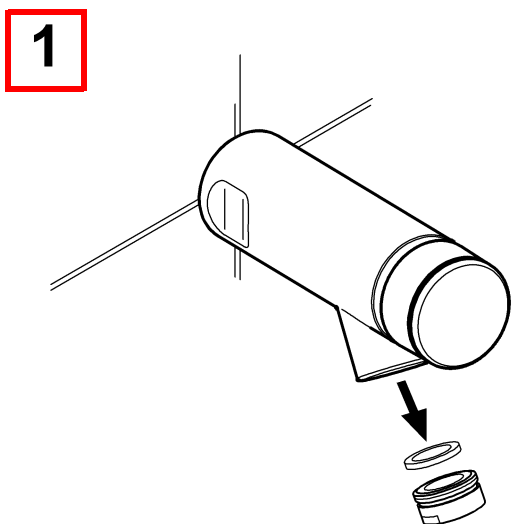

5. Funktionsteil wechseln

EN Remove functional part

NL Functie-element demonteren

CS Demontovat funkční díl

FR Démonter l'élément fonctionnel

PL Wymontować element funkcjonalny

FI Kunnossapito

ES Desmontar la pieza funcional

SV Bygga ut funktionsdelen

RU Демонтаж функциональной

IT Smontaggio dell'elemento funzionale

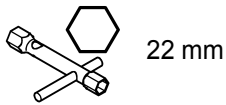

1

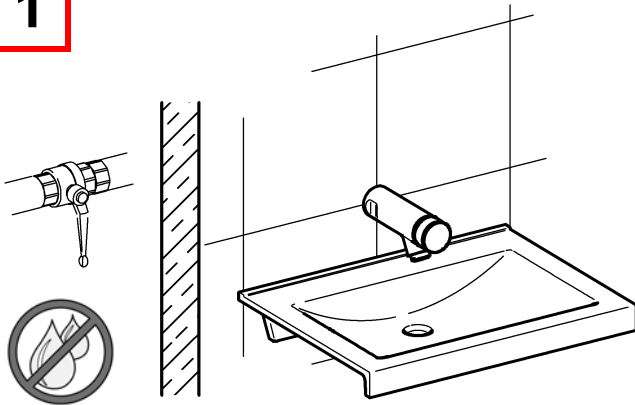

2

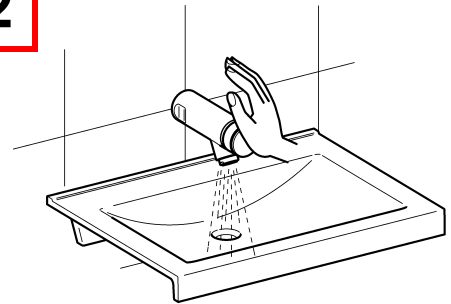

3

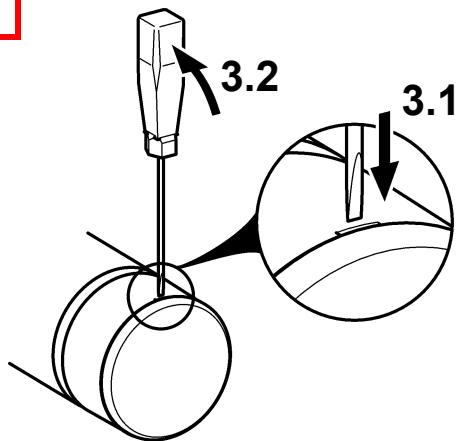

4

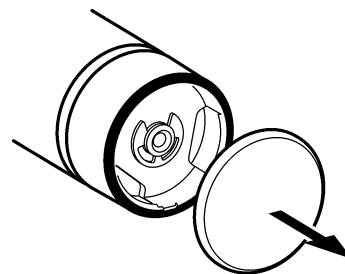

5

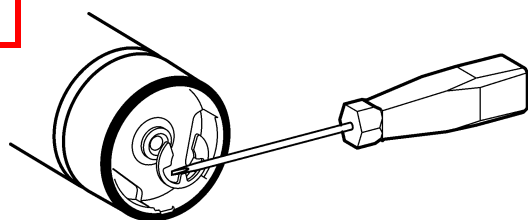

6

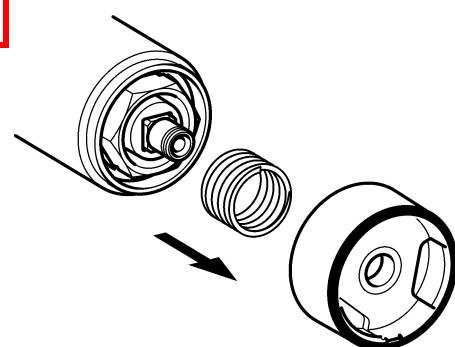

7

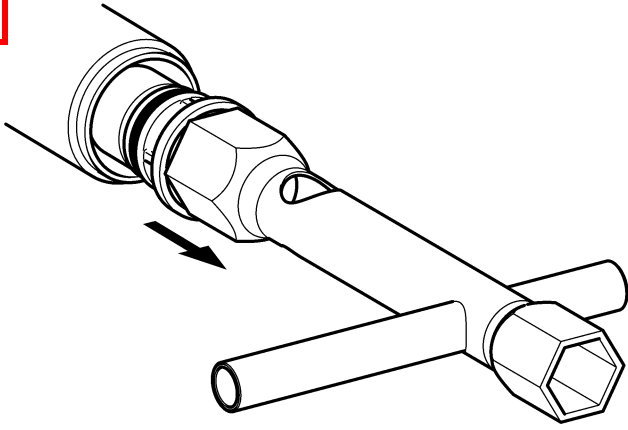

7. Zubehör

EN Accessories
FR Accessoire
ES Accesorios
IT Accessori

NL Toebehoren
PL Akcesoria
SV Tillbehör

CS Příslušenství
FI Lisävarusteet
RU принадлежности

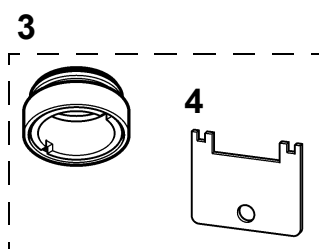
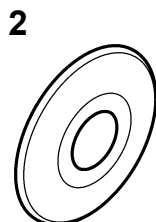
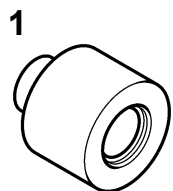

12000101433
ZAQUA002
22000101432
ZAQUA003
32000104778
ZTAPS0005
42000105960
ZFITG0008

Notizen

EN Notes

FR Notes

ES Notas

IT Annotazioni

NL Notities

PL Uwagi

SV Notiser

CS Poznámky

FI Muistiinpanot

RU Примечания

Notizen

EN Notes

FR Notes

ES Notas

IT Annotazioni

NL Notities

PL Uwagi

SV Notiser

CS Poznámky

FI Muistiinpanot

RU Примечания

Australia

PR Kitchen and Water Systems Pty Ltd
Dandenong South VIC 3175
Phone +61 3 9700 9100

Austria

Franke GmbH
6971 Hard
Phone +43 5574 6735 0

Belgium & Luxembourg

Franke N.V.
9400 Ninove, Belgium
Phone +32 54 310 130

Czech Republic

Franke Aquarotter GmbH
14974 Ludwigsfelde, Germany
Phone +420 281 090 429

France

Franke GmbH
6971 Hard, Austria
Phone +33 800 909 216

Germany

Franke Aquarotter GmbH
14974 Ludwigsfelde
Phone +49 3378 818 0

Italy

Franke Water Systems AG
4663 Aarburg, Switzerland
Numero Verde 800 789 233

Middle East

Franke LLC
Ras Al Khaimah, United Arab Emirates
Phone +971 7 2034 700

Morocco

Franke Kitchen System SARL
21 000 Casablanca
Phone +212 522 674 200

Netherlands

Franke N.V.
9400 Ninove, Belgium
Phone +31 492 72 82 24

Poland

Franke Aquarotter GmbH
14974 Ludwigsfelde, Germany
Phone +48 58 35 19 700

Portugal

Franke Portugal S.A.
2735-531 Cacém
Phone +351 21 426 9670

South Africa & Sub Saharan Africa

Franke South Africa
Durban, 4052
Phone + 27 31 450 6300

Spain

Franke GmbH
6971 Hard, Austria
Phone +43 5574 6735 211

Switzerland & Liechtenstein

Franke Water Systems AG
4663 Aarburg
Phone +41 62 787 3131

Turkey

Franke Mutfak ve Banyo Sistemleri
Sanayi ve Ticaret A.S.
41400 Gebze Kocaeli
Phone +90 262 644 6595

United Kingdom

Franke Sissons Ltd.
Barlborough S43 4PZ
Phone +44 1246 450 255

Dart Valley Systems Ltd.

Paignton TQ4 7TW
Phone +44 1803 529 021

EAST EUROPE

**Bosnia Herzegovina | Bulgaria |
Croatia | Hungary | Latvia | Lithuania |
Romania | Russia | Serbia | Slovakia |
Slovenia | Ukraine**

Franke Aquarotter GmbH
14974 Ludwigsfelde, Germany
Phone +49 3378 818 530

NORTH AMERICA

United States | Canada

Franke Kindred Canada Limited
Midland, ON L4R 4K9, Canada
Phone +1 855 446 5663

SCANDINAVIA & ESTONIA

**Finland | Sweden | Norway |
Denmark | Estonia**

Franke Finland Oy
76850 Naarjärvi, Finland
Phone +358 15 34 111

OTHER COUNTRIES

Franke GmbH
6971 Hard, Austria
Phone +43 5574 6735 0