

# ACCESSOIRES



**SD80**

2000056721

7612210002915

DE	Montage- und Betriebsanleitung	Tischseifenspender
EN	Installation and operating instructions	Table soap dispenser
FR	Notice de montage et de mise en service	Distributeur de savon
ES	Instrucciones de montaje y servicio	Dispensador de jabón
IT	Istruzioni per il montaggio e l'uso	Distributore di sapone liquido
NL	Montage- en bedrijfsinstructies	Tafelzeepverdeler
PL	Instrukcja montażu i obsługi	Dozownik mydła do montażu w blacie
SV	Monterings- och driftinstruktion	
CS	Návod pro montáž a provoz	Dávkovač na tekuté mýdlo zabudovate
FI	Asennus- ja käyttöohje	Pöytäsaippua-annostelija
RU	Инструкция по монтажу и вводу в эксплуатацию	

*Make  
it  
Wonderful*

**FRANKE**

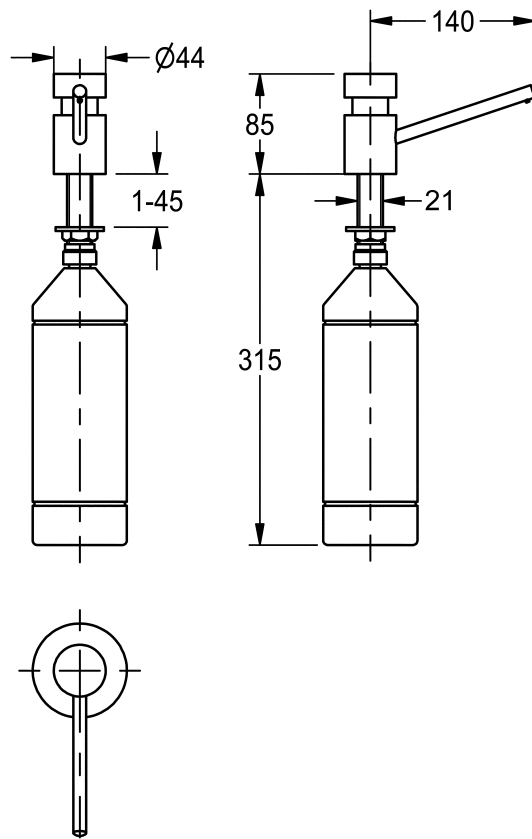
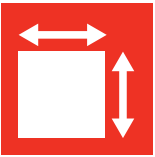
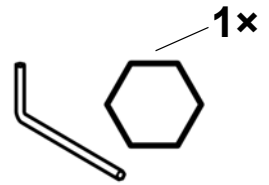
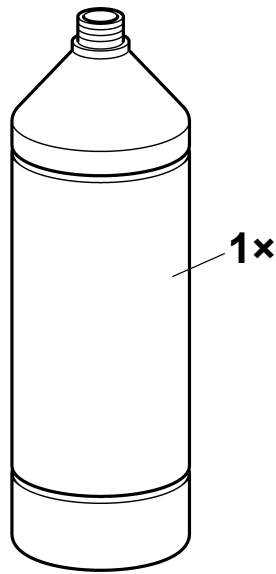
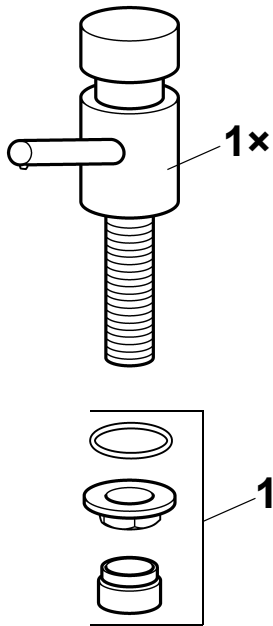

## **EN** Installation and operating instructions

### **Important notes**

- ▶ Use only cream soap or liquid soap!
- ▶ Do not use any soaps with solid contents such as sand or granular material!
- ▶ Use only soaps with a viscosity of 0.01 to 35 dPa s!

## **PL** Instrukcja montażu i obsługi

### **Ważne wskazówki**

- ▶ Stosować wyłącznie mydło w kremie lub płynie!
- ▶ Nie stosować mydła zawierającego ciała stałe jak piasek czy granulát!
- ▶ Stosować wyłącznie mydła o lepkości od 0,01 do 35 dPa s!

## **FR** Notice de montage et de mise en service

### **Remarques importantes**

- ▶ Utiliser uniquement du savon liquide ou sous forme de crème !
- ▶ Ne pas utiliser de savons contenant des matières solides telles que du sable ou des granulés !
- ▶ Utiliser uniquement des savons ayant une viscosité de 0,01 à 35 dPa s!

## **ES** Instrucciones de montaje y servicio

### **Indicaciones importantes**

- ▶ ¡Utilizar únicamente jabón cremoso o líquido!
- ▶ ¡No utilizar jabones con componentes sólidos como arena o granulados!
- ▶ ¡Utilizar sólo jabones con una viscosidad de 0,01 a 35 dPa s!

## **DE** Montage- und Betriebsanleitung

### **Wichtige Hinweise**

- ▶ Nur reine Crem- oder Flüssigseife verwenden!
- ▶ Keine Seifen mit Feststoffanteilen wie Sand oder Granulat verwenden!
- ▶ Nur Seifen mit einer Viskosität von 0,01 bis 35 dPa s verwenden!

## **SV** Monterings- och driftinstruktion

### **Viktiga informationer**

- ▶ Använd bara ren krämtvål eller ren flytande tvål!
- ▶ Använd inte tvål som innehåller fasta partiklar som sand eller granulát!
- ▶ Använd endast tvål med viskositet mellan 0,01 och 35 dPa s!

## **CS** Návod pro montáž a provoz

### **Důležité pokyny**

- ▶ Použijte výhradně jen krémové nebo kapalně mýdlo !
- ▶ Nepoužívejte mýdlo s obsahem pevných podílů, jako je písek nebo granulát !
- ▶ Používejte výhradně jen mýdla s viskozitou od 0,01 do 35 dPa\*s !

## **FI** Asennus- ja käyttöohje

### **Tärkeitä ohjeita**

- ▶ Käytä vain voidemaista tai nestemäistä saippuaa!
- ▶ Älä käytä saippuaa joka sisältää kiinteitä ainesosia kuten hiekkaa tai rakeita!
- ▶ Käytä vain saippuaa jonka viskositeetti on 0,01 – 35 dPa s!

## IT Istruzioni per il montaggio e l'uso

### Avvertenze importanti

- ▶ Utilizzare solamente sapone puro in crema o liquido!
- ▶ Non utilizzare saponi con componenti solide tipo sabbia o granuli!
- ▶ Utilizzare solamente saponi con una viscosità dallo 0,01 ai 35 dPa s!

## RU Инструкция по монтажу и вводу в эксплуатацию

### Важные указания

- ▶ Используйте только чистое кремовое или жидкое мыло!
- ▶ Не используйте мыло с содержанием твёрдых частиц, например песка или гранул!
- ▶ Используйте только мыло с вязкостью от 0,01 до 35 дПа\*с!

## NL Montage- en bedrijfsinstructies

### Belangrijke aanwijzingen

- ▶ Alleen crèmezeep of vloeibare zeep gebruiken!
- ▶ Geen zeep met vaste deeltjes zoals zand of granulaat gebruiken!
- ▶ Alleen zeep met een viscositeit van 0,01 tot 35 dPa s gebruiken!

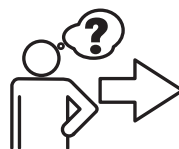
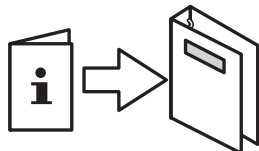
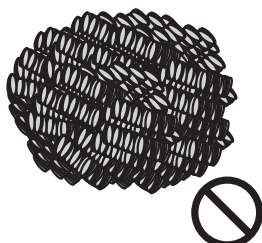
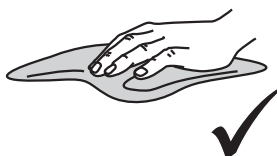

[www.franke.com](http://www.franke.com)

# 1. Montage

EN Installation  
FR Montage  
ES Montaje  
IT Montaggio

NL Montage  
PL Montaż  
SV Montering

CS Montáž  
FI Asennus  
RU Монтаж



 26 mm

**1**

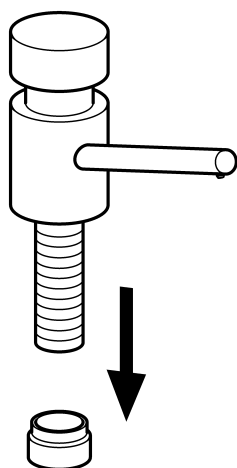

**2**

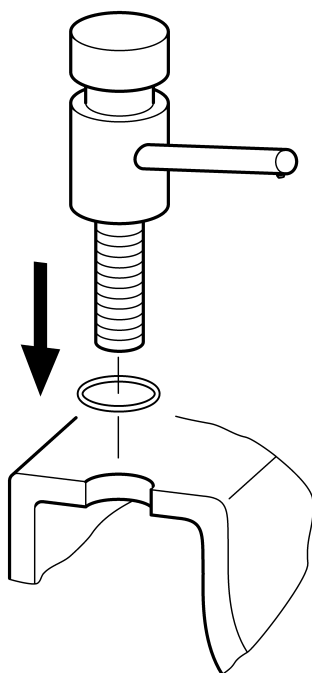

**3**

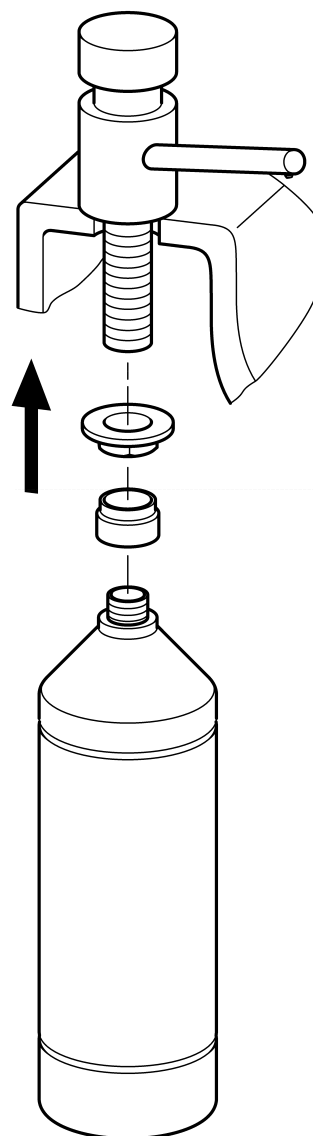

## 2. Tank füllen

EN Fill tank  
FR Remplir réservoir  
ES llenar la cisterna  
IT Riempire il serbatoio

NL Tank vullen  
PL Napełnić zbiornik  
SV Påfyllning av tanken

CS Plnit nádrž  
FI Tankin täyttäminen  
RU заполнить бак

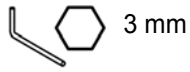

1

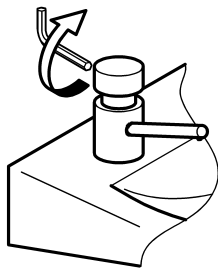

2

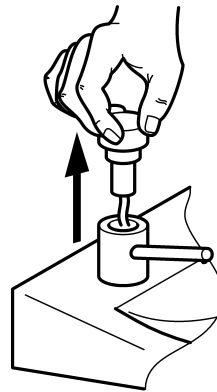

3

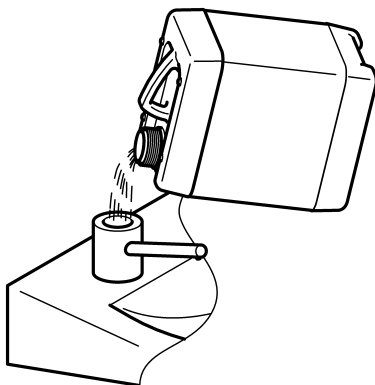

4

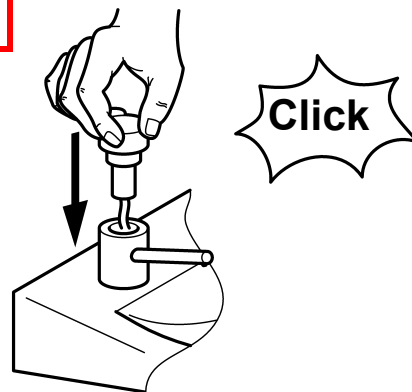

5

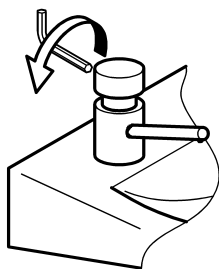

### 3. Funktionsteil wechseln

EN Remove functional part

NL Functie-element demonteren

CS Demontovat funkční díl

FR Démonter l'élément fonctionnel

PL Wymontować element funkcjonalny

FI Kunnossapito

ES Desmontar la pieza funcional

SV Bygga ut funktionsdelen

RU Демонтаж функциональной детали

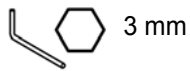

3 mm



11 mm



**1**

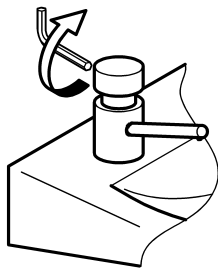

**2**

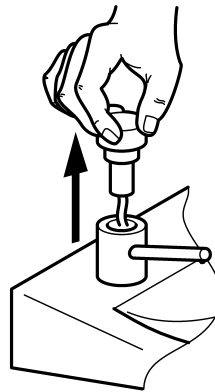

**3**

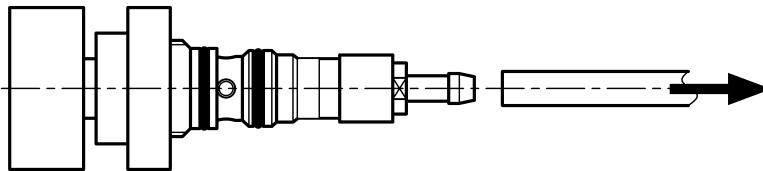

**4**

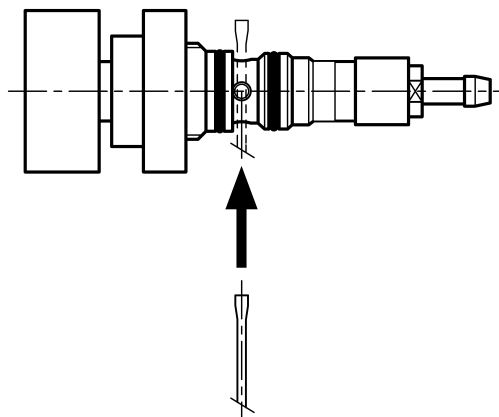

**5**

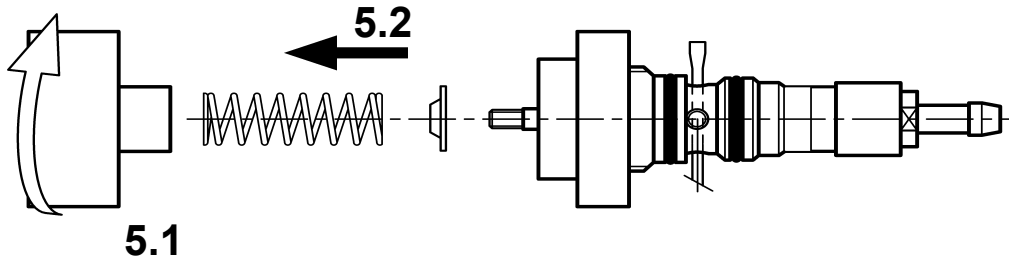

**6**

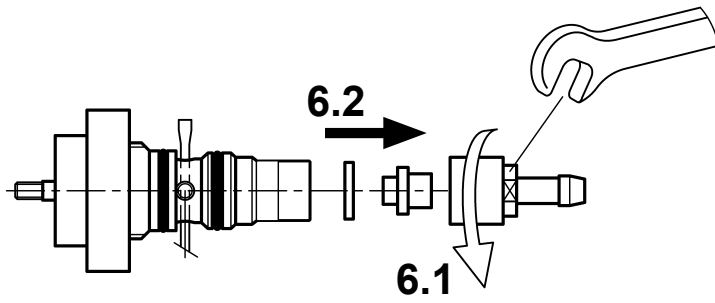

**7**

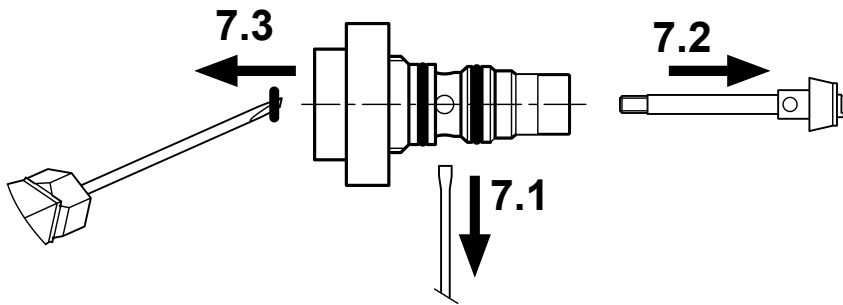

**8**

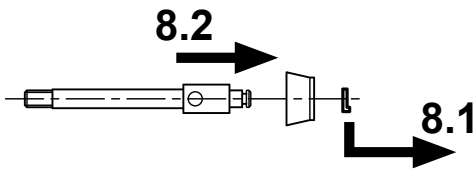



## 4. Ersatzteile

EN Replacement parts  
FR Pièces de rechange  
ES Piezas de recambio  
IT Pezzi di ricambio

NL Reserveonderdelen  
PL Części zamienne  
SV Reservdelar

CS Náhradní díly  
FI Varaosat  
RU Запчасти

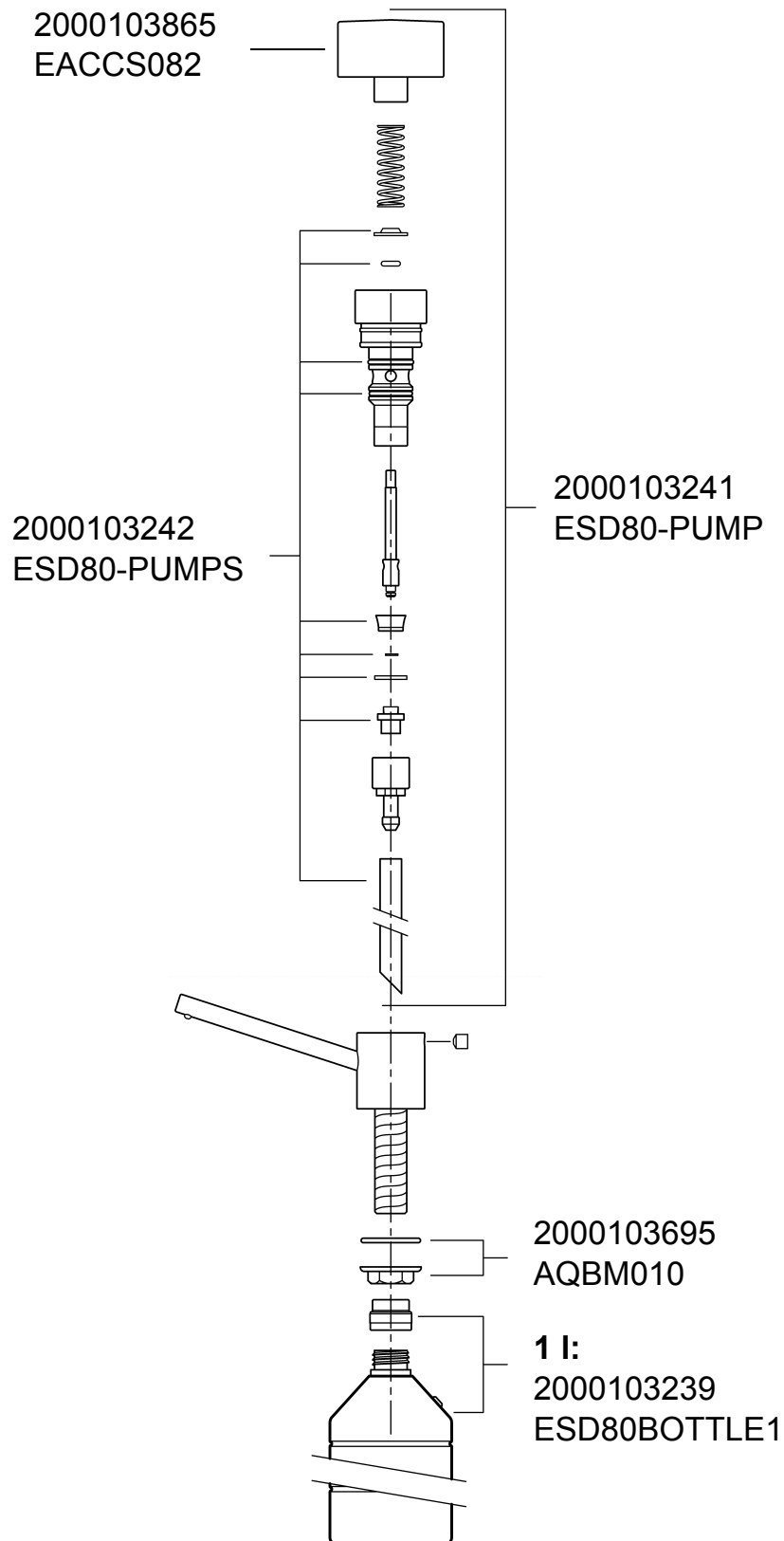

## 5. Zubehör

EN Accessories  
FR Accessoire  
ES Accesorios  
IT Accessori

NL Toebehoren  
PL Akcesoria  
SV Tillbehör

CS Příslušenství  
FI Lisävarusteet  
RU принадлежности

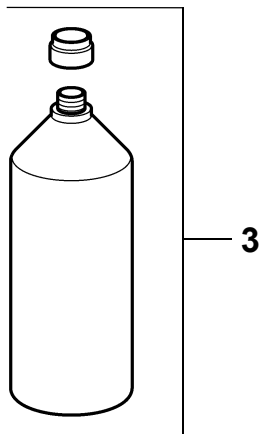
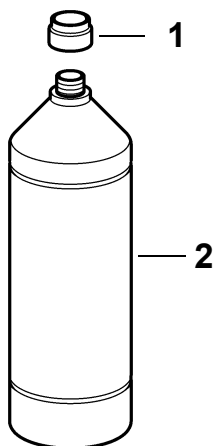

1 .... 2000103729  
EACCS0139

2 .... **500 ml:**  
2000103495  
EACCS085

3 .... **450 ml:**  
2000103728  
EACCS064

4 .... **1 l:**  
2030058103  
SO1LP

5 .... **10 l:**  
2000057168  
SO10L

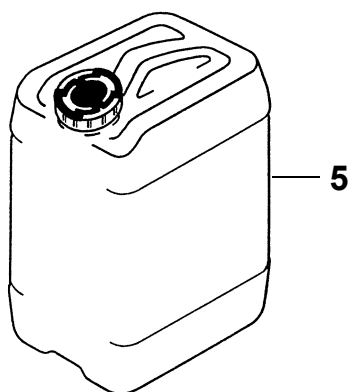
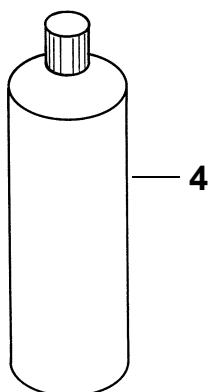

## Notizen

---

EN Notes

FR Notes

ES Notas

IT Annotazioni

NL Notities

PL Uwagi

SV Notiser

CS Poznámky

FI Muistiinpanot

RU Примечания

**Australia**

PR Kitchen and Water Systems Pty Ltd  
Dandenong South VIC 3175  
Phone +61 3 9700 9100

**Austria**

Franke GmbH  
6971 Hard  
Phone +43 5574 6735 0

**Belgium & Luxembourg**

Franke N.V.  
9400 Ninove, Belgium  
Phone +32 54 310 130

**Czech Republic**

Franke Aquarotter GmbH  
14974 Ludwigsfelde, Germany  
Phone +420 281 090 429

**France**

Franke GmbH  
6971 Hard, Austria  
Phone +33 800 909 216

**Germany**

Franke Aquarotter GmbH  
14974 Ludwigsfelde  
Phone +49 3378 818 0

**Italy**

Franke Water Systems AG  
4663 Aarburg, Switzerland  
Numero Verde 800 789 233

**Middle East**

Franke LLC  
Ras Al Khaimah, United Arab Emirates  
Phone +971 7 2034 700

**Morocco**

Franke Kitchen System SARL  
21 000 Casablanca  
Phone +212 522 674 200

**Netherlands**

Franke N.V.  
9400 Ninove, Belgium  
Phone +31 492 72 82 24

**Poland**

Franke Aquarotter GmbH  
14974 Ludwigsfelde, Germany  
Phone +48 58 35 19 700

**Portugal**

Franke Portugal S.A.  
2735-531 Cacém  
Phone +351 21 426 9670

**South Africa & Sub Saharan Africa**

Franke South Africa  
Durban, 4052  
Phone + 27 31 450 6300

**Spain**

Franke GmbH  
6971 Hard, Austria  
Phone +43 5574 6735 211

**Switzerland & Liechtenstein**

Franke Water Systems AG  
4663 Aarburg  
Phone +41 62 787 3131

**Turkey**

Franke Mutfak ve Banyo Sistemleri  
Sanayi ve Ticaret A.S.  
41400 Gebze Kocaeli  
Phone +90 262 644 6595

**United Kingdom**

Franke Sissons Ltd.  
Barlborough S43 4PZ  
Phone +44 1246 450 255

Dart Valley Systems Ltd.

Paignton TQ4 7TW  
Phone +44 1803 529 021

**EAST EUROPE**

**Bosnia Herzegovina | Bulgaria |  
Croatia | Hungary | Latvia | Lithuania |  
Romania | Russia | Serbia | Slovakia |  
Slovenia | Ukraine**

Franke Aquarotter GmbH  
14974 Ludwigsfelde, Germany  
Phone +49 3378 818 530

**NORTH AMERICA**

**United States | Canada**

Franke Kindred Canada Limited  
Midland, ON L4R 4K9, Canada  
Phone +1 855 446 5663

**SCANDINAVIA & ESTONIA**

**Finland | Sweden | Norway |  
Denmark | Estonia**

Franke Finland Oy  
76850 Naarjärvi, Finland  
Phone +358 15 34 111

**OTHER COUNTRIES**

Franke GmbH  
6971 Hard, Austria  
Phone +43 5574 6735 0